



bell 429

bell 429 WLG

Certified Gross Weight Increase to 7,500 lbs

On a Mission.

bell Helicopter®
A Textron Company



BELL 429 | The only light twin designed in the 21st century for your evolving mission requirements.



CORPORATE

There is no compromise when it comes to your comfort. An extremely smooth and quiet ride is just one of the things you will notice in the Bell 429. The large cabin is easily customized for luxurious amenities and the spacious seats provide ample legroom and comfort that makes any trip enjoyable. The large baggage area can easily accommodate both luggage and golf clubs. Whether maximizing your travel time working through papers, or just taking a few minutes to relax and regroup, the Bell 429 provides the right mission environment.



ENERGY

Traveling to offshore oil platforms and windfarms can be tedious and treacherous, so safety and comfort were at the forefront of the Bell 429 design. The flotation system has been designed from the outset to meet the requirements for ditching certification for those operators who require *ditching certification*. Float kits are available with or without integrated life rafts. Raft-equipped flotation systems feature an integral assembly, with rafts and floats contained together for better operational flexibility. Less obvious is the technology incorporated into protecting the Bell 429's airframe and components from the ravages of sea spray and salty air.



HELICOPTER AIR AMBULANCE

Truly an aircraft designed with the air ambulance market in mind. The deck height matches litter height and allows one-man litter loading with less lifting or back strain through either side or optional aft clamshell doors. The largest cabin in its class and structural flat floor affords tremendous mission-to-mission flexibility. Once configured, the large cabin allows full body access, optimizing patient care. The Bell 429 minimizes time en-route so the patient arrives at the medical facility quicker than ever.



PARAPUBLIC

Fast, agile, smooth and quiet, the Bell 429 reduces response time and crew fatigue while expanding an agency's mission capabilities. Exceptional cabin volume, large cabin doors and optional rear clamshell doors easily accommodate special mission equipment, tactical deployments or hoist operations. Even the tallest crew member wearing an NVG-equipped helmet is comfortable flying the Bell 429 thanks to best-in-class cabin volume and fully adjustable seats and pedals. Coupled with a fully integrated glass cockpit, with options that include moving maps, multi-sensor camera imagery and NVG capability, the Bell 429 delivers the complete multi-role parapublic package.

A white Bell 429 helicopter with red and grey stripes is shown in flight against a blue sky with light clouds. The helicopter is viewed from a low angle, showing its side profile. The main rotor blades are blurred due to motion. The tail rotor is also blurred. The text 'Bell 429' is visible on the side of the fuselage. A 'DANGER' warning is visible on the tail boom.

Bell 429

Designed with the future in mind, the Bell 429 meets or exceeds today's airworthiness requirements to enhance occupant safety, with the adaptability to remain at the forefront as mission requirements evolve. Innovation is at the heart of the Bell 429 light twin helicopter. The usage of metallic and composite parts in its construction creates the perfect balance between rigidity and flexibility, safety and durability. An advanced avionics and systems monitoring suite ensures outstanding maintainability and aircraft readiness. Coupled with exceptional construction and attention to detail, the Bell 429 is truly unsurpassed in its class.

CLASS-LEADING FEATURES:

- Certified to meet or exceed the latest airworthiness and occupant safety requirements from the FAA, TCAA and EASA
- Certified for single pilot IFR and all Category A profiles
- Certified to 20,000 ft/6,096 m maximum operating altitude with operating temperatures from -40° to 51.7°C/-40° to 125.06°F
- 1st helicopter with revolutionary MSG-3 Certified Maintenance Program
- Improved safety and maintenance efficiency, with significant items addressed at the system level
- Spacious intermediate size cabin offers the best value in its class, with pricing and DOCs comparable to smaller light twins
- Fully adjustable crew seats move fore and aft, up and down, and include adjustable lumbar support
- Versatile track-mounted seats allow cabin seating to be reconfigured or removed in just minutes for maximum utility
- Rear cabin doors slide aft, hugging the fuselage for easier hot loading and operation with doors open in flight
- Excellent fore and aft CG tolerance permits flexible load distribution, without the need for adding ballast
- Optional clamshell doors open with minimal effort and hug the fuselage for convenient operation in strong winds or while the aircraft is running
- Excellent lateral stability easily permits 600 lbs/272 kg to be hoisted outside of the skid gear

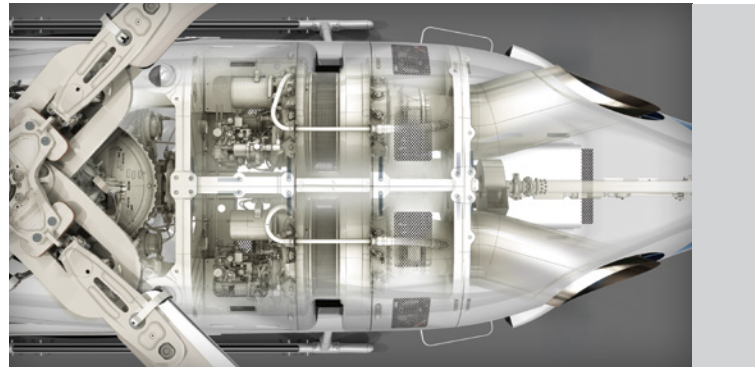

ECONOMIC TWIN PERFORMANCE

Equipped with two proven Pratt & Whitney Canada engines, the Bell 429 provides superior Category A performance, outstanding hover performance and cruise speeds at economic costs. Electronic engine controls are pilot friendly and operationally simple with a full hydro-mechanical backup and auto-starting. Backed by the industry leader in aftermarket support, these engines require no special tools for line maintenance and have quick access to Line Replaceable Units (LRUs) for fast removal/installation.



SUPERIOR HIGH HOT PERFORMANCE

Innovative rotor blades, powerful engines and a strong transmission combine to provide a new level of performance at all altitudes and temperatures. At high heat and maximum gross weight, the Bell 429 can perform an OGE hover at 5,660 ft/1,725 m; IGE hover at 8,690 ft/2,649 m and engage in takeoff and landing operations in excess of 13,000 ft/3,962 m.



CABIN & COCKPIT COMFORT

Comfort doesn't take a backseat to performance in the Bell 429. The largest passenger cabin in its class provides excellent headroom so the passengers can relax in a smooth and extremely quiet ride. The large windows provide greater visibility creating an exceptional flight experience.



WHEELED LANDING GEAR

Delivering exceptional speed, range and hover performance, the Bell 429WLG offers retractable nose and main landing gear for ground taxi operations. Ground taxiing reduces pilot workload and enables safe movement of the aircraft while taxiing near other aircraft. The Bell 429WLG is available with optional retractable landing gear doors kit and optional emergency flotation kit.



RUGGED CONSTRUCTION

Designed from the outset as a 21st century airframe, the Bell 429 utilizes an ultra-rigid machined alloy airframe with composite external skins, sharing construction characteristics more commonly found in the most advanced military jets. The result is a spacious, rigid airframe with exceptional resistance to fatigue and adverse environmental conditions.



FULLY-INTEGRATED GLASS FLIGHT DECK

Advanced software performs workload-reducing calculations, including IGE, OGE, and Category A profiles, weight and balance, and power assurance checks, in addition to self diagnostics and exceedance monitoring. There's also a Power Situation Indicator (PSI) display that further reduces pilot workload and improves situational awareness.

INTERNAL GROSS WEIGHT INCREASE

In our constant effort to provide increased customer value, Bell Helicopter is pleased a growing number of countries have adopted Transport Canada's approval of an internal gross weight increase kit, which takes the Bell 429 internal gross weight from 7,000 lbs/3,175 kg to 7,500 lbs/3,402 kg, providing a useful load of 3,012 lbs/1,366 kg.

THE KIT INCLUDES:

- Flight Manual Supplement
- Helicopter Terrain Awareness Warning System (HTAWS)
- Cockpit Voice Recorder/Flight Data Recorder (CVR/FDR)
- Flashing Forward Light
- Radar Altimeter

Note: Internal gross weight increase is available in select regions. Contact your Bell Helicopter sales representative for further information.

SINGLE PILOT IFR CERTIFIED

Situational awareness is maximized and pilot workload is minimized through a fully integrated glass flight deck featuring modern large format flat panel displays and a Bell Helicopter designed advanced automatic flight control system. This advanced design provides single pilot IFR certification for the standard helicopter, and dual and single pilot IFR certification when the co-pilot controls and instruments are added.

OUTSTANDING OEI PERFORMANCE

No matter the situation, the Bell 429's powerful engines and high OEI rated transmission provide superior single-engine performance. Certified for Category A operations from ground level helipads, elevated helipads, runways at maximum gross weight, on hot days and at altitude means almost no mission or operating environment is beyond your reach.

WORLD-CLASS CUSTOMER SUPPORT AND TRAINING

Bell Helicopter's renowned network of worldwide support and service is one of the many benefits of operating a Bell 429. With a significant parts inventory pre-positioned at global supply centers, plus training and technical personnel ready to answer your questions and provide the support you need in the field, Bell Helicopter is committed to providing you with the best products backed by the best service in the industry.

To further complement our support, a comprehensive set of Bell 429 pilot and maintainer courses are available through the world-class Bell Helicopter Training Academy (BTA). Pilots will appreciate a suite of customized course materials, complemented by a sophisticated flight training device, and concluding with flight instruction in a BTA operated Bell 429. The BTA also understands that the right training is just as important as comprehensive training, so your Bell 429 instruction can be custom tailored to meet your specific goals and training requirements.



Delivering exceptional speed, range, hover performance and enhanced safety margins, the Bell 429 also offers operators a state-of-the-art single pilot IFR helicopter with top user-rated in-service support.

TECHNICAL SPECIFICATIONS

SPEEDS at optional maximum gross weight	Bell 429 - IGV		Bell 429WLG	
V _{NE}	155 kts	287 km/h	155 kts	287 km/h
Max Cruise	148 kts	274 km/h	154 kts	284 km/h
Range at V _{LRC} ¹	403 nm	746 km	412 nm	763 km
Max Endurance at Loiter Speed ¹	4.4 hrs		4.4 hrs	
CEILING ALTITUDES				
Service Ceiling (Pressure Altitude)	20,000 ft	6,096 m	20,000 ft	6,096 m
Hover Ceiling IGE (Optional Max GW, ISA)	12,070 ft	3,679 m	12,070 ft	3,679 m
Hover Ceiling OGE (Optional Max GW, ISA)	9,150 ft	2,789 m	9,150 ft	2,789 m
CAPACITIES				
Standard Seating	1 + 7		1 + 7	
Standard Fuel	217 US gal	821 liters	217 US gal	821 liters
Auxiliary Fuel (Optional)	39 US gal	148 liters	39 US gal	148 liters
Cabin Floor Space	32.7 ft ²	3.04 m ²	32.7 ft ²	3.04 m ²
Total Cabin Volume (Including Aft Cabin) ²	204 ft ³	5.78 m ³	204 ft ³	5.78 m ³
Aft (Baggage) Compartment Volume	74 ft ³	2.1 m ³	74 ft ³	2.1 m ³
WEIGHTS				
Empty Weight (Standard Configuration, Optional Max GW) ³	4,488 lbs	2,036 kg	4,733 lbs	2,147 kg
Useful Load (Internal, Standard Configuration, Optional Max GW)	3,012 lbs	1,366 kg	2,767 lbs	1,255 kg
Minimum Empty Weight (SPIFR, Optional Max GW) ⁴	4,235 lbs	1,921 kg	4,485 lbs	2,034 kg
Max Useful Load (Internal, SPIFR, Optional Max GW)	3,265 lbs	1,481 kg	3,015 lbs	1,368 kg
Max Gross Weight (Internal, Optional Max GW)	7,500 lbs	3,402 kg	7,500 lbs	3,402 kg
Max Gross Weight (External Load)	7,500 lbs	3,402 kg	7,500 lbs	3,402 kg
Cargo Hook Capacity	3,000 lbs	1,361 kg	3,000 lbs	1,361 kg
POWERPLANT (2) Pratt & Whitney Canada PW207D1				
Transmission Rating, MCP	1,100 shp	820 kW	1,100 shp	820 kW

¹ Optional max GW, ISA, Std. fuel – no reserve, at 4,000 ft/1,219 m

² Total contiguous area, including baggage compartment. Does not include copilot volume of 28 ft³/0.8 m³

³ Standard configuration includes:

- Provisions for optional equipment including Cat. A operations, inlet barrier filter, air conditioning, rotor brake and wire strike protection system provisions
- ELT
- Pilot & co-pilot seats
- 6-place passenger seating with 18.5 in wide seats
- Standard interior, headliner panels and carpet
- Increased Internal Gross Weight Kit (optional)

⁴ Minimum SPIFR configuration includes:

- Provisions for optional equipment including Cat. A operations, inlet barrier filter, air conditioning, rotor brake and wire strike protection system provisions
- ELT
- Pilot seat

